

Battery Protection IC For 3-Serial or 4-Serial-Cell Pack

S-8243A/B Series

The S-8243A/B is a series of lithium-ion rechargeable battery protection ICs incorporating high-accuracy battery protection circuits, a battery monitor amp and a voltage regulator.

The S-8243A/B is suitable for protection of 3-serial or 4-serial cell lithium-ion battery packs from overcharge, overdischarge and overcurrent.

■ Features

- (1) High-accuracy voltage detection for each cell
 - Overcharge detection voltage n (n=1 to 4)

3.9 V to 4.4 V (50 mV step)	Accuracy ±25 mV
-----------------------------	-----------------
 - Hysteresis voltage n (n=1 to 4) of overcharge detection

-0.10 V to -0.40 V (50 mV step) or 0 V	Accuracy ±50 mV
--	-----------------

(Overcharge release voltage n (=Overcharge detection voltage n + Hysteresis voltage n) can be selected within the range 3.8 V to 4.4 V.)
 - Overdischarge detection voltage n (n=1 to 4)

2.0 V to 3.0 V (100 mV step)	Accuracy ±80 mV
------------------------------	-----------------
 - Hysteresis voltage n (n=1 to 4) of overdischarge detection

0.20 V to 0.70 V or 0 V (100 mV step)	Accuracy ±100 mV
---------------------------------------	------------------

(Overdischarge release voltage n (=Overdischarge detection voltage n + Hysteresis voltage n) can be selected within the range 2.0 V to 3.4 V.)
- (2) Three-level overcurrent protection including protection for short-circuiting
 - Overcurrent detection voltage 1 0.05 V to 0.3 V (50 mV step) Accuracy ±25 mV
 - Overcurrent detection voltage 2 0.5 V Accuracy ±100 mV
 - Overcurrent detection voltage 3 $V_{DD}/2$ Accuracy ± 15 %
- (3) Delay times for overcharge detection, overdischarge detection and overcurrent detection 1 can be set by external capacitors. (Delay times for overcurrent detection 2 and 3 are fixed internally.)
- (4) Charge/discharge operation can be controlled through the control pins.
- (5) High-accuracy battery monitor amp $GAMP = V_{BATTERY} \times 0.2 \pm 1.0\%$
- (6) Voltage regulator $V_{OUT} = 3.3 V \pm 2.4\% (3 \text{ mA max.})$
- (7) High input-voltage device Absolute maximum rating: 26 V
- (8) Wide operating voltage range 6 V to 18 V
- (9) Wide operating temperature range: -40°C to +85 °C
- (10) Low current consumption

Operation mode	120 μA max.
Power down mode	0.1 μA max.
- (11) Small package 16-Pin TSSOP package

■ Applications

- Lithium-ion rechargeable battery packs
- Lithium- polymer rechargeable battery packs

■ Package

- 16-Pin TSSOP (Package drawing code : FT016-A)

■ **Block Diagram**

S-8243B series

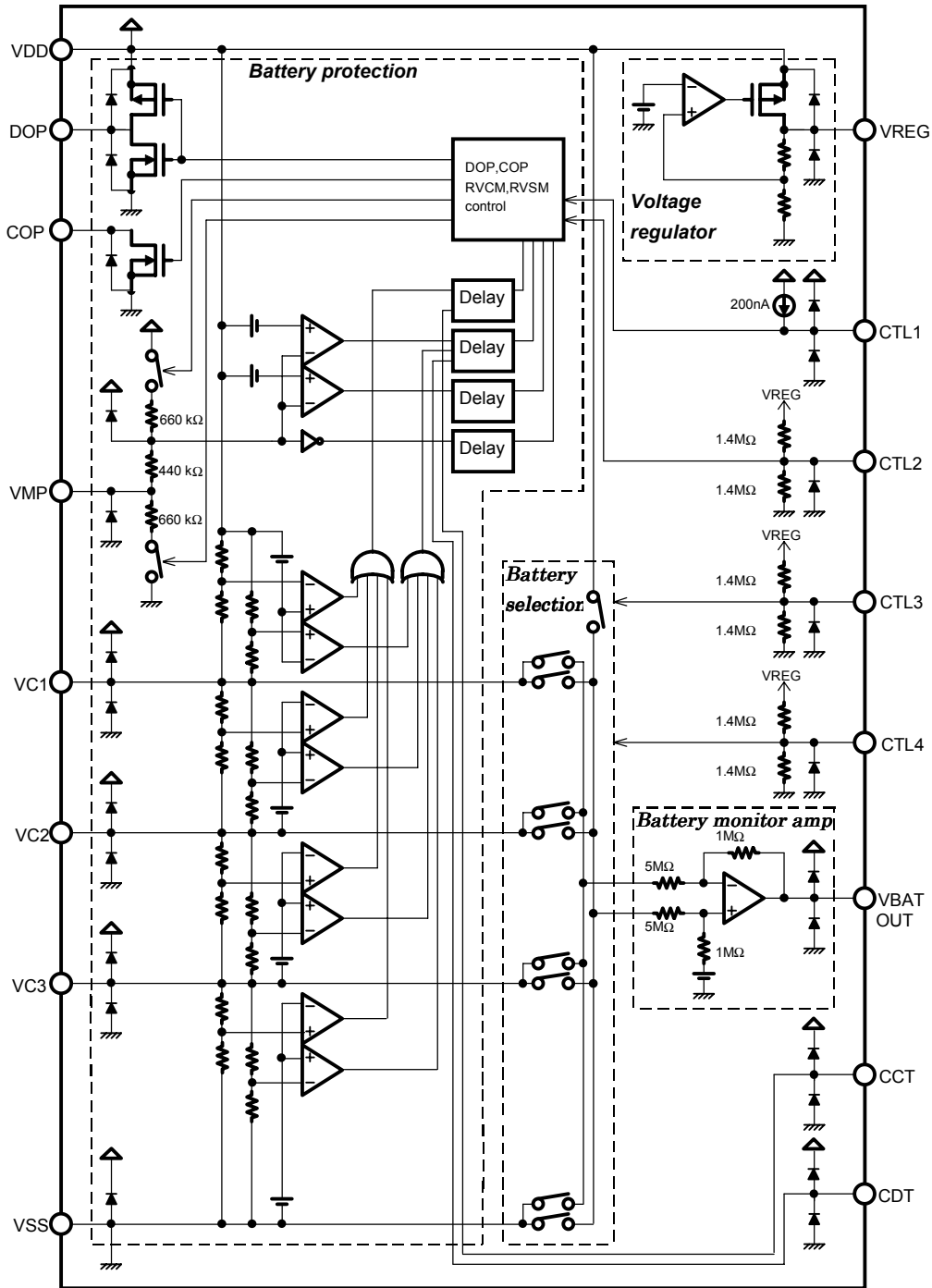

Note: 1. Diodes in the figure are parasitic diodes. 2. Numerical values are typical values.

3. For the case of S-8243A series, which is designed for 3-serial cell, VC1 and VC2 pin should be shorted, internal of the IC.

Figure 1 Block Diagram

■ Selection Guide

S-8243A series is designed for 3-serial cell pack.

S-8243B series is designed for 4-serial cell pack.

Table.1 S-8243A Series (3-serial cell)

Product name	Overcharge detection voltage	Hysteresis voltage for overcharge detection	Overdischarge detection voltage	Hysteresis voltage for overdischarge detection	Overcurrent detection voltage ¹	0V battery charging function
S-8243AACFT	4.35 ± 0.025 V	-0.15 ± 0.05 V	2.40 ± 0.08 V	0.20 ± 0.10 V	0.20 V ± 0.025 V	Available
S-8243AADFT	4.35 ± 0.025 V	-0.35 ± 0.05 V	2.40 ± 0.08 V	0 V	0.20 V ± 0.025 V	Available

Note. Change in the detection voltage is available in products other than listed above. Contact the SII sales office.

Table.2 S-8243B Series (4-serial cell)

Product name	Overcharge detection voltage	Hysteresis voltage for overcharge detection	Overdischarge detection voltage	Hysteresis voltage for overdischarge detection	Overcurrent detection voltage ¹	0V battery charging function
S-8243BADFT	4.35 ± 0.025 V	-0.25 ± 0.05 V	2.40 ± 0.08 V	0 V	0.25 V ± 0.025 V	Available
S-8243BAEFT	4.35 ± 0.025 V	-0.15 ± 0.05 V	2.40 ± 0.08 V	0.20 ± 0.10 V	0.20 V ± 0.025 V	Available
S-8243BAFFT	4.25 ± 0.025 V	-0.25 ± 0.05 V	2.40 ± 0.08 V	0 V	0.20 V ± 0.025 V	Available

Note. Change in the detection voltage is available in products other than listed above. Contact the SII sales office.

■ Absolute Maximum Ratings

Table 3 (Ta = 25°C unless otherwise specified)

Parameter	Symbol	Applied Pins	Rating	Unit
Input voltage VDD	V _{DS}	—	V _{SS} -0.3 to V _{SS} +26	V
Input voltage	V _{IN}	VC1,VC2,VC3,CCT,CDT	V _{SS} -0.3 to V _{DD} +0.3	V
VMP pin Input voltage	V _{Mp}	VMP	V _{SS} -0.3 to V _{SS} +26	V
DOP pin output voltage	V _{DOP}	DOP	V _{SS} -0.3 to V _{DD} +0.3	V
COP pin output voltage	V _{COP}	COP	V _{SS} -0.3 to V _{SS} +26	V
VREG pin output voltage	V _{OUT}	VREG	V _{SS} -0.3 to V _{DD} +0.3	V
CTL1 pin input voltage	V _{CTL1}	CTL1	V _{SS} -0.3 to V _{DD} +0.3	V
CTL2 to CTL4 pin input voltage	V _{CTLn}	CTL2,CTL3,CTL4	V _{SS} -0.3 to V _{OUT} +0.3	V
Cell voltage output voltage	V _{BATOUT}	VBATOUT	V _{SS} -0.3 to V _{OUT} +0.3	V
Power dissipation	P _D	16-Pin TSSOP	300	mW
Operating temperature range	T _{opr}	—	-40 to +85	°C
Storage temperature range	T _{stg}	—	-40 to +125	°C

Note: Although the IC contains protection circuit against static electricity, excessive static electricity or voltage which exceeds the limit of the protection circuit should not be applied to.

Pin Assignment

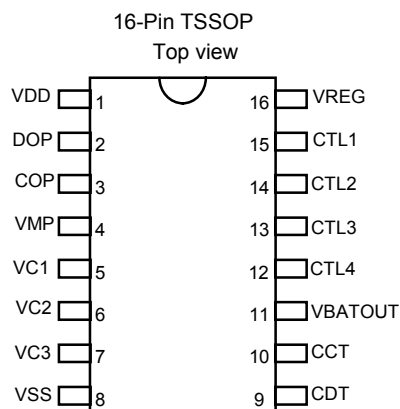

Figure 2

Pin Description

Table 4

No	Name	Description for A series	Description for B series
1	VDD	Positive power input pin. Battery 1 positive voltage connection pin	
2	DOP	FET gate connection pin for discharge control (CMOS output)	
3	COP	FET gate connection pin for charge control (Nch open-drain output)	
4	VMP	Voltage detection pin between VDD and VMP(Over current detection pin)	
5	VC1	No connection	Battery1 negative voltage and battery 2 positive voltage connection pin
6	VC2	Battery1 negative voltage and battery 2 positive voltage connection pin	Battery 2 negative voltage and battery 3 positive voltage connection pin
7	VC3	Battery 2 negative voltage and battery 3 positive voltage connection pin	Battery 3 negative voltage and battery 4 positive voltage connection pin
8	VSS	Negative power input pin. Battery 3 negative voltage connection pin	Negative power input pin. Battery 4 negative voltage connection pin
9	CDT	Capacitor connection pin for overdischarge detection delay time and over current detection1 delay time	
10	CCT	Capacitor connection pin for overcharge detection delay time	
11	VBATOUT	Output pin for each battery voltage and offset	
12	CTL4	Battery selection control signal input	
13	CTL3	Battery selection control signal input	
14	CTL2	Charge and discharge control signal input	
15	CTL1	Charge and discharge control signal input	
16	VREG	3.3 V voltage regulator output	

Electrical Characteristics

(1) S-8243A series

Table 5

(Ta = 25°C unless otherwise specified)

Parameter	Symbol	Conditions	Min.	Typ.	Max.	Unit	Test circuit
BATTERY PROTECTION							
Overcharge detection voltage n n=1, 2, 3	V _{CU_n}	3.9 V to 4.4 V 50 mV Step	V _{CU_n} −0.025	V _{CU_n}	V _{CU_n} +0.025	V	4
Hysteresis voltage n of overcharge detection n=1, 2, 3	V _{H_{Cn}}	−0.10 V to −0.40 V, and 0 V	V _{H_{Cn}} −0.05	V _{H_{Cn}}	V _{H_{Cn}} +0.05	V	4
Overdischarge detection voltage n=1, 2, 3	V _{DL_n}	2.0 V to 3.0 V 100 mV Step	V _{DL_n} −0.08	V _{DL_n}	V _{DL_n} +0.08	V	4
Hysteresis voltage n of Overdischarge detection n=1, 2, 3	V _{HD_n}	0.20 V to 0.70 V, and 0 V	V _{HD_n} −0.10	V _{HD_n}	V _{HD_n} +0.10	V	4
Overcurrent detection voltage 1	V _{IOV1}	0.05 V to 0.3 V 50 mV Step	V _{IOV1} −0.025	V _{IOV1}	V _{IOV1} +0.025	V	4
Overcurrent detection voltage 2	V _{IOV2}	—	V _{DD} −0.60	V _{DD} −0.50	V _{DD} −0.40	V	4
Overcurrent detection voltage 3	V _{IOV3}	—	V _{DD} ×0.425	V _{DD} ×0.5	V _{DD} ×0.575	V	4
Temperature coefficient for detection and release voltage ⁽¹⁾	T _{COE1}	Ta= −5°C to 55°C	−1.0	0	1.0	mV/°C	4
Temperature coefficient for overcurrent detection voltage ⁽²⁾	T _{COE2}	Ta= −5°C to 55°C	−0.5	0	0.5	mV/°C	4
0 V BATTERY CHARGING FUNCTION The 0 V battery function is either "0 V battery charging is allowed." or "0 V battery charging is inhibited." depending upon the product type.							
0 V battery charge starting charger voltage	V _{0CHA}	0 V battery charging allowed	—	0.8	1.5	V	7
0 V battery charge inhibition battery voltage	V _{0INH}	0 V battery charging inhibited	0.4	0.7	1.1	V	7
INTERNAL RESISTANCE							
Internal resistance between VMP and VDD	R _{VDM}	V1=V2=V3=3.5 V	500	1100	2400	kΩ	8
Internal resistance between VMP and VSS	R _{VSM}	V1=V2=V3=1.8 V	300	700	1500	kΩ	8
VOLTAGE REGULATOR							
Output voltage	V _{OUT}	V _{DD} =14 V, I _{OUT} =3 mA	3.221	3.300	3.379	V	2
Line regulation	ΔV _{OUT1}	V _{DD} =6 V→18 V, I _{OUT} =3 mA	—	5	15	mV	2
Load regulation	ΔV _{OUT2}	V _{DD} =14 V, I _{OUT} =5 μA→3 mA	—	15	30	mV	2
BATTERY MONITOR AMP							
Input offset voltage n n=1, 2, 3	V _{OFF_n}	V1=V2=V3=3.5 V	60	165	270	mV	3
Voltage gain n n=1, 2, 3	GAMP _n	V1=V2=V3=3.5 V	0.2×0.99	0.2	0.2×1.01	—	3
INPUT VOLTAGE, OPERATING VOLTAGE							
Operating voltage between V _{DD} and V _{SS}	V _{DSOP}	—	6	—	18	V	4
CTL1 input voltage for High	V _{CTL1H}	—	V _{DD} ×0.8	—	—	V	6
CTL1 input voltage for Low	V _{CTL1L}	—	—	—	V _{DD} ×0.2	V	6
CTLn input voltage for High n=2, 3, 4	V _{CTL_nH}	—	V _{OUT} ×0.9	—	V _{OUT}	V	3, 6
CTLn input voltage for Low n=2, 3, 4	V _{CTL_nL}	—	—	—	V _{OUT} ×0.1	V	3, 6

Table 5 (continued)

Parameter	Symbol	Remarks	Min.	Typ.	Max.	Unit	Test circuit
INPUT CURRENT							
Current consumption at not monitoring V_{BATOUT}	I_{OPE}	$V1=V2=V3=3.5\text{ V}$ $V_{MP}=V_{DD}$	—	65	120	μA	1
Current consumption at power down	I_{PDN}	$V1=V2=V3=1.5\text{ V}$ $V_{MP}=V_{SS}$	—	—	0.1	μA	1
Current for VCN at not monitoring V_{BATOUT} ($n=2, 3$)	I_{VCnN}	$V1=V2=V3=3.5\text{ V}$	-0.3	0	0.3	μA	3
Current for VC2 at monitoring of V_{BATOUT}	I_{VC2}	$V1=V2=V3=3.5\text{ V}$	—	2.0	7.2	μA	3
Current for VC3 at monitoring of V_{BATOUT}	I_{VC3}	$V1=V2=V3=3.5\text{ V}$	—	1.0	4.0	μA	3
Current for CTL1 at Low	I_{CTL1L}	$V1=V2=V3=3.5\text{ V}$ $V_{CTL1}=0\text{ V}$	-0.4	-0.2	—	μA	5
Current for CTLn at High $n=2,3,4$	I_{CTLnH}	$V_{CTLn}=V_{OUT}$	—	2.5	5	μA	9
Current for CTLn at Low $n=2,3,4$	I_{CTLnL}	$V_{CTLn}=0\text{ V}$	-5	-2.5	—	μA	9
OUTPUT CURRENT							
Leak current COP	I_{COH}	$V_{COP}=24\text{ V}$	—	—	0.1	μA	9
Sink current COP	I_{COL}	$V_{COP}=V_{SS}+0.5\text{ V}$	10	—	—	μA	9
Source current DOP	I_{DOH}	$V_{DOP}=V_{DD}-0.5\text{ V}$	10	—	—	μA	9
Sink current DOP	I_{DOL}	$V_{DOP}=V_{SS}+0.5\text{ V}$	10	—	—	μA	9
Source current V_{BATOUT}	I_{VBATH}	$V_{BATOUT}=V_{DD}-0.5\text{ V}$	100	—	—	μA	9
Sink current V_{BATOUT}	I_{VBATL}	$V_{BATOUT}=V_{SS}+0.5\text{ V}$	100	—	—	μA	9

Applied to S-8243AACFT and S-8243AADFT

Parameter	Symbol	Conditions	Min.	Typ.	Max.	Unit	Test circuit
DELAY TIME							
Overcharge detection delay time	t_{CU}	$C_{CT}=0.1\ \mu\text{F}$	0.5	1.0	1.5	s	5
Overdischarge detection delay time	t_{DL}	$C_{DT}=0.1\ \mu\text{F}$	50	100	150	ms	5
Overcurrent detection delay time 1	t_{IOV1}	$C_{DT}=0.1\ \mu\text{F}$	5	10	15	ms	5
Overcurrent detection delay time 2	t_{IOV2}	—	1.5	2.5	4.0	ms	4
Overcurrent detection delay time 3	t_{IOV3}	—	100	300	600	μs	4

- (1) Temperature coefficient for detection and release voltage is applied to overcharge detection voltage n, overcharge release voltage n, overdischarge detection voltage n, and overdischarge release voltage n.
- (2) Temperature coefficient for overcurrent detection voltage is applied to over current detection voltage 1 and 2.

(2) S-8243B series

Table 6

(Ta = 25°C unless otherwise specified)

Parameter	Symbol	Conditions	Min.	Typ.	Max.	Unit	Test circuit
DETECTION VOLTAGE							
Overcharge detection voltage n n=1, 2, 3, 4	V _{CU_n}	3.9 V to 4.4 V 50 mV Step	V _{CU_n} −0.025	V _{CU_n}	V _{CU_n} +0.025	V	4
Hysteresis voltage n of overcharge detection n=1, 2, 3, 4	V _{HC_n}	−0.10 V to −0.40 V, and 0 V	V _{HC_n} −0.05	V _{HC_n}	V _{HC_n} +0.05	V	4
Overdischarge detection voltage n=1, 2, 3, 4	V _{DL_n}	2.0 V to 3.0 V 100 mV Step	V _{DL_n} −0.08	V _{DL_n}	V _{DL_n} +0.08	V	4
Hysteresis voltage n of Overdischarge detection n=1, 2, 3, 4	V _{HD_n}	0.20 to 0.70, and 0	V _{HD_n} −0.10	V _{HD_n}	V _{HD_n} +0.10	V	4
Overcurrent detection voltage 1	V _{IOV1}	0.05 V to 0.3 V 50 mV Step	V _{IOV1} −0.025	V _{IOV1}	V _{IOV1} +0.025	V	4
Overcurrent detection voltage 2	V _{IOV2}	—	V _{DD} −0.60	V _{DD} −0.50	V _{DD} −0.40	V	4
Overcurrent detection voltage 3	V _{IOV3}	—	V _{DD} ×0.425	V _{DD} ×0.5	V _{DD} ×0.575	V	4
Temperature coefficient for detection and release voltage ⁽¹⁾	T _{COE1}	Ta= −5°C to 55°C	−1.0	0	1.0	mV/°C	4
Temperature coefficient for overcurrent detection voltage ⁽²⁾	T _{COE2}	Ta= −5°C to 55°C	−0.5	0	0.5	mV/°C	4
0V BATTERY CHARGING FUNCTION The 0 V battery function is either "0 V battery charging is allowed." or "0 V battery charging is inhibited." depending upon the product type.							
0 V battery charge starting charger voltage	V _{0CHA}	0 V battery charging allowed	—	0.8	1.5	V	7
0 V battery charge inhibition battery voltage	V _{0INH}	0 V battery charging inhibited	0.4	0.7	1.1	V	7
INTERNAL RESISTANCE							
Internal resistance between VMP and VDD	R _{VDM}	V1=V2=V3=V4=3.5 V	500	1100	2400	kΩ	8
Internal resistance between VMP and VSS	R _{VSM}	V1=V2=V3=V4=1.8 V	300	700	1500	kΩ	8
VOLTAGE REGULATOR							
Output voltage	V _{OUT}	V _{DD} =14V, I _{OUT} =3 mA	3.221	3.300	3.379	V	2
Line regulation	ΔV _{OUT1}	V _{DD} =6 V→18 V, I _{OUT} =3 mA	—	5	15	mV	2
Load regulation	ΔV _{OUT2}	V _{DD} =14 V, I _{OUT} =5 μA→3 mA	—	15	30	mV	2
BATTERY MONITOR AMP							
Input offset voltage n n=1, 2, 3, 4	V _{OFF_n}	V1=V2=V3= V4=3.5 V	60	165	270	mV	3
Voltage gain n n=1, 2, 3, 4	GAMP _n	V1=V2=V3= V4=3.5 V	0.2×0.99	0.2	0.2×1.01	—	3
INPUT VOLTAGE, OPERATING VOLTAGE							
Operating voltage between V _{DD} and V _{SS}	V _{DSOP}	—	6	—	18	V	4
CTL1 input voltage for High	V _{CTL1H}	—	V _{DD} ×0.8	—	—	V	6
CTL1 input voltage for Low	V _{CTL1L}	—	—	—	V _{DD} ×0.2	V	6
CTLn input voltage for High n=2, 3, 4	V _{CTL_nH}	—	V _{OUT} ×0.9	—	V _{OUT}	V	3, 6
CTLn input voltage for Low n=2, 3, 4	V _{CTL_nL}	—	—	—	V _{OUT} ×0.1	V	3, 6

Table 6 (continued)

Parameter	Symbol	Remarks	Min.	Typ.	Max.	Unit	Test circuit
INPUT CURRENT							
Current consumption at not monitoring V_{BATOUT}	I_{OPE}	$V1=V2=V3=V4=3.5\text{ V}$ $V_{MP}=V_{DD}$	—	65	120	μA	1
Current consumption at power down	I_{PDN}	$V1=V2=V3=V4=1.5\text{ V}$ $V_{MP}=V_{SS}$	—	—	0.1	μA	1
Current for VCn at not monitoring V_{BATOUT} (n=1, 2, 3)	I_{VCnN}	$V1=V2=V3=V4=3.5\text{ V}$	-0.3	0	0.3	μA	3
Current for VC1 at monitoring of V_{BATOUT}	I_{VC1}	$V1=V2=V3=V4=3.5\text{ V}$	—	3.2	10.4	μA	3
Current for VC2 at monitoring of V_{BATOUT}	I_{VC2}	$V1=V2=V3=V4=3.5\text{ V}$	—	2.0	7.2	μA	3
Current for VC3 at monitoring of V_{BATOUT}	I_{VC3}	$V1=V2=V3=V4=3.5\text{ V}$ $V_{CTL1}=0\text{ V}$	—	1.0	4.0	μA	3
Current for CTL1 at Low	I_{CTL1L}	$V1=V2=V3=V4=3.5\text{ V}$ $V_{CTL1}=0\text{ V}$	-0.4	-0.2	—	μA	5
Current for CTLn at High n=2,3,4	I_{CTLnH}	$V_{CTLn}=V_{OUT}$	—	2.5	5	μA	9
Current for CTLn at Low n=2,3,4	I_{CTLnL}	$V_{CTLn}=0\text{ V}$	-5	-2.5	—	μA	9
OUTPUT CURRENT							
Leak current COP	I_{COH}	$V_{COP}=24\text{ V}$	—	—	0.1	μA	9
Sink current COP	I_{COL}	$V_{COP}=V_{SS}+0.5\text{ V}$	10	—	—	μA	9
Source current DOP	I_{DOH}	$V_{DOP}=V_{DD}-0.5\text{ V}$	10	—	—	μA	9
Sink current DOP	I_{DOL}	$V_{DOP}=V_{SS}+0.5\text{ V}$	10	—	—	μA	9
Source current V_{BATOUT}	I_{VBATH}	$V_{BATOUT}=V_{DD}-0.5\text{ V}$	100	—	—	μA	9
Sink current V_{BATOUT}	I_{VBATL}	$V_{BATOUT}=V_{SS}+0.5\text{ V}$	100	—	—	μA	9

Applied to S-8243BAEFT and S-8243BAFFT

Parameter	Symbol	Conditions	Min.	Typ.	Max.	Unit	Test circuit
DELAY TIME							
Overcharge detection delay time	t_{CU}	$C_{CT}=0.1\ \mu\text{F}$	0.5	1.0	1.5	s	5
Overdischarge detection delay time	t_{DL}	$C_{DT}=0.1\ \mu\text{F}$	50	100	150	ms	5
Overcurrent detection delay time 1	t_{IOV1}	$C_{DT}=0.1\ \mu\text{F}$	5	10	15	ms	5
Overcurrent detection delay time 2	t_{IOV2}	—	1.5	2.5	4.0	ms	4
Overcurrent detection delay time 3	t_{IOV3}	—	100	300	600	μs	4

Applied to S-8243BADFT

Parameter	Symbol	Conditions	Min.	Typ.	Max.	Unit	Test circuit
DELAY TIME							
Overcharge detection delay time	t_{CU}	$C_{CT}=0.1\ \mu\text{F}$	0.5	1.0	1.5	s	5
Overdischarge detection delay time	t_{DL}	$C_{DT}=0.1\ \mu\text{F}$	55.5	111	222	ms	5
Overcurrent detection delay time 1	t_{IOV1}	$C_{DT}=0.1\ \mu\text{F}$	3.31	6.62	13.2	ms	5
Overcurrent detection delay time 2	t_{IOV2}	—	1.5	2.5	4.0	ms	4
Overcurrent detection delay time 3	t_{IOV3}	—	100	300	600	μs	4

- (1) Temperature coefficient for detection and release voltage is applied to overcharge detection voltage n, overcharge release voltage n, overdischarge detection voltage n, and overdischarge release voltage n.
- (2) Temperature coefficient for overcurrent detection voltage is applied to over current detection voltage 1 and 2.

■ Test circuits

In this chapter test methods are explained for the case of S-8243B series, which is designed for 4-serial cell pack. For the case of S-8243A series, which is designed for 3-serial cell, voltage source V2 should be shorted, V3 should be read as V2, and V4 as V3.

1. Current consumption (Test circuit 1)

Current consumption at not monitoring V_{BATOUT} , I_{OPE} , is a current measured at the VSS pin when $V1 = V2 = V3 = V4 = 3.5\text{ V}$ and $V_{MP} = V_{DD}$. Current consumption at power down, I_{PDN} , is a current measured at the VSS pin when $V1 = V2 = V3 = V4 = 1.5\text{ V}$ and $V_{MP} = V_{SS}$.

2. Voltage regulator (Test circuit 2)

Output voltage of the regulator V_{OUT} is a voltage measured at the VREG pin when $V_{DD} = V_{MP} = 14\text{ V}$ and $I_{OUT} = 3\text{ mA}$.

Line regulation of the voltage regulator ΔV_{OUT1} is defined by the equation $\Delta V_{OUT1} = V_{OUT2} - V_{OUT1}$ where V_{OUT1} is the output voltage when $V_{DD} = V_{MP} = 6\text{ V}$ and $I_{OUT} = 3\text{ mA}$, and V_{OUT2} is the output voltage when $V_{DD} = V_{MP} = 18\text{ V}$ and $I_{OUT} = 3\text{ mA}$.

Load regulation of the regulator is defined by the equation $\Delta V_{OUT2} = V_{OUT3} - V_{OUT}$ where V_{OUT3} is the output voltage when $V_{DD} = V_{MP} = 14\text{ V}$ and $I_{OUT} = 5\text{ }\mu\text{A}$.

3. Battery monitor amp and pin current for VC1 to VC3 (Test circuit 3)

Voltage gain of the battery monitor amp for each cell is defined by the input offset voltage and the measurement result provided from the VBATOUT pin for the combination of the CTL3 pin and CTL4 pin expressed by the following table at the condition where $V1 = V2 = V3 = V4 = 3.5\text{ V}$. Pin current for VC1 to VC3, I_{VCn} and I_{VCnN} are at the same time measured.

Table 7

CTL3 pin status	CTL4 pin status	VBATOUT output	VCn (n=1, 2, 3) pin current
$V_{CTL3H}\text{ min.}$	$V_{CTL4H}\text{ min.}$	V_{OFF1}	I_{VC1} at VC1 pin
$V_{CTL3H}\text{ min.}$	Open	V_{BAT1}	—
$V_{CTL3H}\text{ min.}$	$V_{CTL4L}\text{ max.}$	V_{OFF2}	I_{VC2} at VC2 pin
Open	$V_{CTL4H}\text{ min.}$	V_{BAT2}	—
Open	Open	V_{OFF3}	I_{VC3} at VC3 pin
Open	$V_{CTL4L}\text{ max.}$	V_{BAT3}	—
$V_{CTL3L}\text{ max.}$	$V_{CTL4H}\text{ min.}$	V_{OFF4}	I_{VCnN} at VCn pin (n=1, 2, 3)
$V_{CTL3L}\text{ max.}$	Open	V_{BAT4}	—

Voltage gain of the battery monitor amp for each cell is calculated by the equation

$$GAMPn = (V_{BATn} - V_{OFFn}) / Vn \quad (n = 1 \text{ to } 4)$$

4. Overcharge detection voltages, overcharge detection hysteresis, overdischarge detection voltages, overdischarge detection hysteresis, and overcurrent detection voltages (Test circuit 4)

⟨⟨Overcharge detection voltages, hysteresis voltages, and overdischarge detection voltages⟩⟩

In the following $V_{MP} = V_{DD}$ and the CDT pin is open.

The COP pin and the DOP pin should provide “Low”, which is a voltage equal to $V_{DD} \times 0.1\text{ V}$ or lower, in the condition that $V1 = V2 = V3 = V4 = 3.5\text{ V}$.

The overcharge detection voltage V_{CU1} is defined by the voltage at which COP pin voltage becomes “High”, which is a voltage equal to $V_{DD} \times 0.9\text{ V}$ or higher, when the voltage V1 is gradually increased from the starting condition $V1 = 3.5\text{ V}$. The overcharge release voltage V_{CL1} is defined by the voltage at which COP pin voltage becomes “Low” when the voltage V1 is gradually decreased. The hysteresis voltage of the overcharge detection V_{HC1} is then defined by the difference between the overcharge detection voltage V_{CU1} and the overcharge release voltage V_{CL1} .

The overdischarge detection voltage V_{DL1} is defined by the voltage at which DOP pin voltage becomes “High” when the voltage V1 is gradually decreased from the starting condition $V1 = 3.5\text{ V}$. The overdischarge release voltage V_{DU1} is defined by the voltage at which DOP pin voltage becomes “Low” when the voltage V1 is gradually increased. The hysteresis of the overdischarge detection voltage V_{HD1} is then defined by the difference between the overdischarge release voltage V_{DU1} and the overdischarge detection voltage V_{DL1} .

Other overcharge detection voltage V_{CU_n} , hysteresis voltage of overcharge detection V_{HC_n} , overdischarge detection voltage V_{DL_n} , and hysteresis of the overdischarge detection voltage V_{HD_n} (for $n = 2$ to 4) are defined in the same manner as in the case for $n = 1$.

<<Overcurrent detection voltages>>

Starting condition is $V1 = V2 = V3 = V4 = 3.5\text{ V}$, $V_{MP} = V_{DD}$, and the CDT pin is open. The DOP pin voltage thus provides “Low”

The overcurrent detection voltage 1, V_{IOV1} is defined by the voltage difference $V_{DD} - V_{MP}$ at which the DOP pin voltage becomes “High” when the voltage of VMP pin is decreased.

Starting condition for measuring the overcurrent detection voltage 2 and 3 is $V1 = V2 = V3 = V4 = 3.5\text{ V}$, $V_{MP} = V_{DD}$ and the CDT pin voltage $V_{CDT} = V_{SS}$. The DOP pin voltage thus provides “Low”.

The overcurrent detection voltage 2, V_{IOV2} is defined by the voltage difference $V_{DD} - V_{MP}$ at which the DOP pin voltage becomes “High” when the voltage of VMP pin is decreased.

The overcurrent detection delay time 2, t_{IOV2} is a time needed for the DOP pin to become “High” from “Low” when the VM pin voltage is changed quickly to $V_{IOV2} \text{ min.} - 0.2\text{ V}$ from the starting condition $V_{MP} = V_{DD}$.

The overcurrent detection voltage 3, V_{IOV3} is defined by the voltage of the VM pin at which the DOP pin voltage becomes “High” when the voltage of VMP pin is decreased at the speed 10 V/ms .

The overcurrent detection delay time 3, t_{IOV3} is a time needed for the DOP pin to become “High” from “Low” when the VM pin voltage is changed quickly to $V_{IOV3} \text{ min.} - 0.2\text{ V}$ from the starting condition $V_{MP} = V_{DD}$.

5. CTL1 pin current, overcharge detection delay, overdischarge detection delay, and overcurrent detection delay 1 (Test circuit 5)

Starting condition is $V1 = V2 = V3 = V4 = 3.5\text{ V}$ and $V_{MP} = V_{DD}$.

Current which flows between the CTL1 pin and V_{SS} is the CTL1 pin current I_{CTL1L} .

The overcharge detection delay time t_{CU} is a time needed for the COP pin voltage to change from “Low” to “High” just after the V1 voltage is rapidly increased from 3.5 V to 4.5 V .

The overdischarge detection delay time t_{DL} is a time needed for the DOP pin voltage to change from “Low” to “High” just after the V1 voltage is rapidly decreased from 3.5 V to 1.5 V .

The overcurrent detection delay time 1 is a time needed for the DOP pin voltage to change from “Low” to “High” just after the VMP pin voltage is decreased from V_{DD} to $V_{DD} - 0.35\text{ V}$ when $V1 = 3.5\text{ V}$.

6. Input voltages for CTL1 and CTL2 (Test circuit 6)

Starting condition is $V1 = V2 = V3 = V4 = 3.5\text{ V}$.

Pin voltages of the COP and the DOP should be “High” when $V_{CTL1} = V_{CTL1H} \text{ min.}$ and CTL2 is OPEN.

Pin voltages of the COP and the DOP should be “Low” when $V_{CTL1} = V_{CTL1L} \text{ max.}$ and CTL2 is OPEN.

Pin voltage of the COP is “High” and the pin voltage of the DOP is “Low” when $V_{CTL1} = V_{CTL1L} \text{ max.}$ and $V_{CTL2} = V_{CTL2H} \text{ min.}$

Pin voltage of the COP is “Low” and the pin voltage of the DOP is “High” when $V_{CTL1} = V_{CTL1L} \text{ max.}$ and $V_{CTL2} = V_{CTL2L} \text{ max.}$

7. 0 V battery charge starting charger voltage and 0 V battery charge inhibition battery voltage (Test circuit 7)

One of the 0 V battery charge starting charger voltage and 0 V battery charge inhibition battery voltage is applied to each product according to the 0V battery charging function.

Starting condition is $V1 = V2 = V3 = V4 = 0\text{ V}$ for a product in which 0 V battery charging is available.

The COP pin voltage should be lower than $V_{0CHA} \text{ max.} - 1\text{ V}$ when the VMP pin voltage $V_{MP} = V_{0CHA} \text{ max.}$

Starting condition is $V1 = V2 = V3 = V4 = V_{0INH}$ for a product in which 0 V battery charging is inhibited.

The COP pin voltage should be higher than $V_{MP} - 1\text{ V}$ when the VMP pin voltage $V_{MP} = 24\text{ V}$.

8. Internal resistance (Test circuit 8)

The resistance between VDD and VMP is R_{VDM} and is calculated by the equation $R_{VDM} = V_{DD} / I_{VDM}$ where I_{VDM} is a VMP pin current after V_{MP} is changed to V_{SS} from the starting condition $V1 = V2 = V3 = V4 = 3.5\text{ V}$ and $V_{MP} = V_{DD}$.

The resistance between VSS and VMP is R_{VSM} and is calculated by the equation $R_{VSM} = V_{DD} / I_{VSM}$ where I_{VSM} is a VMP pin current at the condition $V1 = V2 = V3 = V4 = 1.8\text{ V}$ and $V_{MP} = V_{DD}$.

9. Pin current for CTL2 to CTL4, COP, DOP, VBATOUT (Test circuit 9)

Starting condition is $V1 = V2 = V3 = V4 = 3.5\text{ V}$.

Pin current for CTL2 at "High" is I_{CTL2H} and is obtained by setting $V_{CTL2} = V_{OUT}$.

Pin current for CTL2 at "Low" is I_{CTL2L} and is obtained by setting $V_{CTL2} = V_{SS}$.

Pin current for CTL3 and CTL4 can be obtained in the same manner as in the CTL2.

Pin current for COP at "High" is I_{COH} and is obtained by setting $V1 = V2 = V3 = V4 = 6\text{ V}$, $V_{MP} = V_{DD}$, and $V_{COP} = V_{DD}$. And pin current for COP at "Low" is I_{COL} and is obtained by setting $V1 = V2 = V3 = V4 = 3.5\text{ V}$, $V_{MP} = V_{DD}$, and $V_{COP} = 0.5\text{ V}$.

Pin current for DOP at "Low" is I_{DOL} and is obtained by setting $V1 = V2 = V3 = V4 = 3.5\text{ V}$, $V_{MP} = V_{DD}$, and $V_{DOP} = 0.5\text{ V}$. And pin current for COP at "High" is I_{COH} and is obtained by setting $V1 = V2 = V3 = V4 = 3.5\text{ V}$, $V_{MP} = V_{DD} - 1\text{ V}$, and $V_{DOP} = V_{DD} - 0.5\text{ V}$.

Pin current for VBATOUT at "High" is I_{VBATH} and is obtained by setting CTL3 and CTL4 are open and $V_{BATOUT} = V_{OFF3} - 0.5\text{ V}$. And pin current for VBATOUT at "Low" is I_{VBATL} and is obtained by setting $V_{BATOUT} = V_{OFF3} + 0.5\text{ V}$.

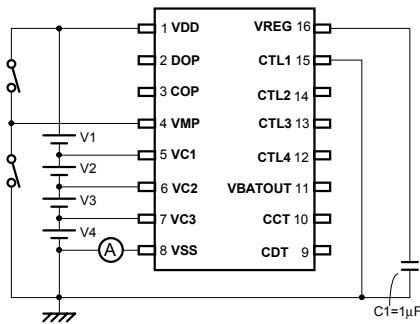

Test circuit 1

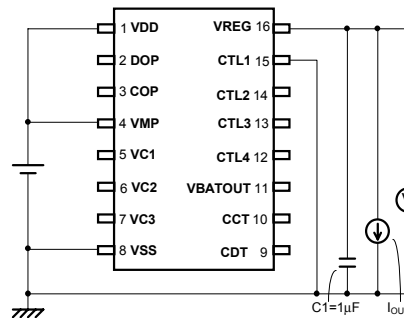

Test circuit 2

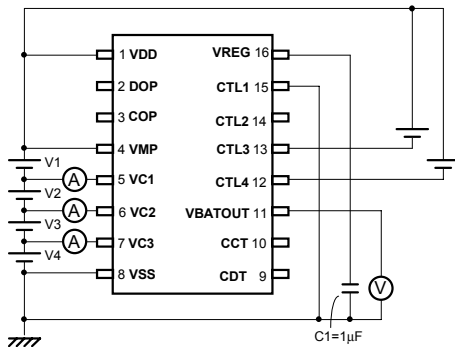

Test circuit 3

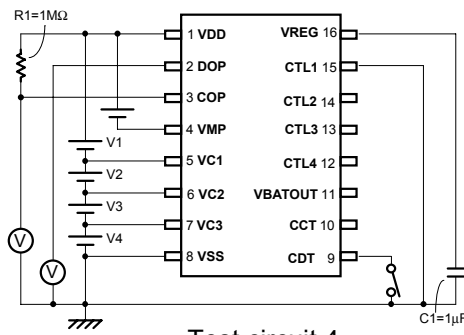

Test circuit 4

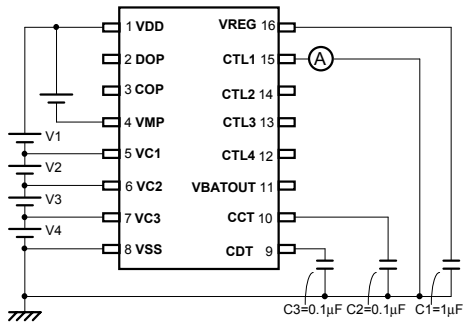

Test circuit 5

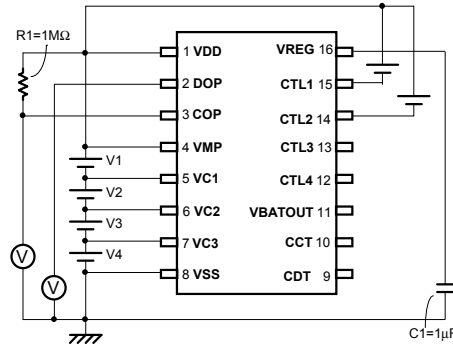

Test circuit 6

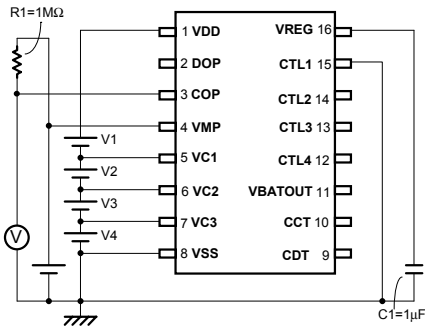

Test circuit 7

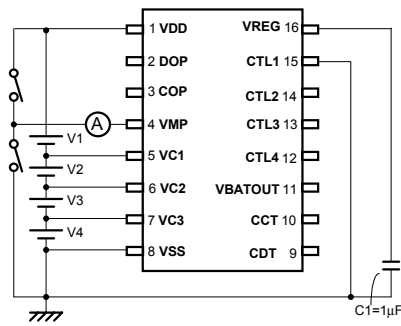

Test circuit 8

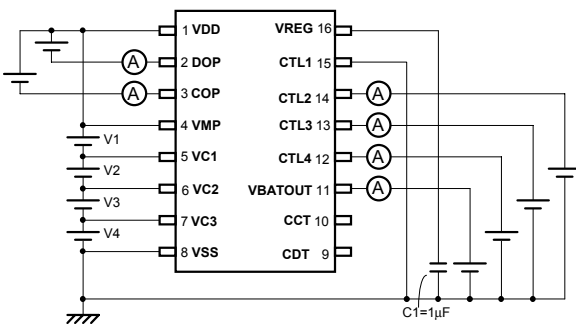

Test circuit 9

■ Description of operation

1. Battery protection circuit

Battery protection protects batteries from overcharge and overdischarge, and also protects external FETs from overcurrent.

1-1 Normal condition

When all of the battery voltages are in the range from V_{DLn} to V_{CU_n} and the discharge current is lower than a specified value (the VMP pin voltage is lower than V_{IOV1}), the charging and discharging FETs are turned on.

1-2 Overcharge condition

When any one of the battery voltages becomes higher than V_{CU_n} and the state continues for t_{CU} or longer,

the COP pin becomes high impedance and is pulled up to EB+ pin voltage by an external resistor, and the charging FET is turned off to stop charging. The overcharge condition is released when one of the following two conditions holds.

- a) All battery voltages become lower than $V_{CU_n} + V_{HC_n}$.
- b) $V_{DD} - V_{MP} > V_{IOV1}$ (A load is connected, and discharging starts.)

1-3 Overdischarge condition

When any one of the battery voltages becomes lower than V_{DL_n} and the state continues for t_{DL} or longer, the DOP pin voltage becomes V_{DD} level, and the discharging FET is turned off to stop discharging. After discharging is stopped due to overdischarge condition, the S-8243 enters power down condition.

1-4 Power down condition

After stopping discharging due to overdischarge condition, the S-8243 enters power down condition. In this condition, almost all circuits of the S-8243 are stopped to save current consumption. The current consumption becomes lower than I_{PDN} . In the power down condition, the VMP pin is pulled down to V_{SS} level by the internal R_{VSM} resistor. In power down condition, output pin voltages are fixed at the following levels.

- a) COP V_{SS} (Charging FET is turned on)
- b) DOP V_{DD} (Discharging FET is turned off)
- c) VREG V_{SS} (Voltage regulator circuit is off)
- d) VBATOUT V_{SS} (Battery voltage monitor amp circuit is off)

The power down condition is released when the following condition holds.

- a) $V_{MP} > V_{IOV3}$ (A charger is connected, and charging starts.)

1-5 Overcurrent condition

The S-8243 has three overcurrent detection levels (V_{IOV1} , V_{IOV2} and V_{IOV3}) and three overcurrent detection delay times (t_{IOV1} , t_{IOV2} and t_{IOV3}) corresponding to each overcurrent detection levels. When the discharging current becomes higher than a specified value (the voltage between V_{DD} and V_{MP} is greater than V_{IOV1}) and the state continues for t_{IOV1} or longer, the S-8243 enters the overcurrent condition in which the DOP pin voltage becomes V_{DD} level to turn off the discharging FET to stop discharging, the COP pin becomes high impedance and is pulled up to EB+ pin voltage by an external resistor to turn off the charging FET to stop charging, and the VMP pin is pulled up to V_{DD} voltage by the internal resistor R_{VDM} . Operation of two other overcurrent detection levels (V_{IOV2} and V_{IOV3}) and overcurrent detection delay times (t_{IOV2} and t_{IOV3}) is the same as that for V_{IOV1} and t_{IOV1} .

The overcurrent condition is released when the following condition holds.

- a) $V_{MP} > \{V_{IOV3} / (1 - V_{IOV3}) \times 3 / 5 - 2 / 5\} \times R_{VDM}$
(A load is released, and the impedance between the EB- and EB+ pin becomes higher.)

1-6 0 V battery charging function

Regarding the charging of a self-discharged battery (0 V battery) the S-8243 has two functions from which one should be selected.

- a) 0 V battery charging is allowed (0 V battery charging is available)
When a charger voltage is higher than V_{0CHA} , 0 V battery can be charged.
- b) 0 V battery charging is forbidden (0 V battery charging is impossible)
When one of the battery voltages is lower than V_{0INH} , 0 V battery can not be charged.

Note: When the VDD pin voltage is lower than minimum of V_{DSOP} , the operation of S-8243 series is not guaranteed.

1-7 Delay time setting

Overcharge detection delay times (t_{CU1} to t_{CU4}) are determined by the external capacitor at the CCT pin. Overdischarge detection delay times (t_{DL1} to t_{DL4}) and overcurrent detection delay time 1 (t_{IOV1}) are determined by the external capacitor at CDT pin. Overcurrent detection delay time 2,3 (t_{IOV2}, t_{IOV3}) are fixed internally.

S-8243AAC, AAD, BAE, BAF

	min.	typ.	max.	
$t_{CU}[s]$ = Delay factor (5	10	15) $\times C_{CT}[\mu F]$
$t_{DL}[ms]$ = Delay factor (500	1000	1500) $\times C_{DT}[\mu F]$
$t_{IOV1}[ms]$ = Delay factor (50	100	150) $\times C_{DT}[\mu F]$

S-8243BAD

	min.	typ.	max.	
$t_{CU}[s]$ = Delay factor (5	10	15) $\times C_{CT}[\mu F]$
$t_{DL}[ms]$ = Delay factor (555	1110	2220) $\times C_{DT}[\mu F]$
$t_{IOV1}[ms]$ = Delay factor (33.1	66.2	132) $\times C_{DT}[\mu F]$

2. Voltage regulator circuit

Built-in voltage regulator can be used to drive a micro computer, etc. The voltage regulator supplies voltage of 3.3 V (3 mA maximum) and an external capacitor is needed.

Note: In the power down condition the voltage regulator output is pulled down to the V_{SS} level by an internal resistor.

3. Battery monitor amp circuit

Battery monitor amp sends information of the batteries to a microcomputer. The battery monitor amp output is controlled and selected by CTL3 and CTL4 pins to give the following two voltages.

- $V_{BATn} = GAMPn \times V_{BATTERYn} + V_{OFFn}$ where $GAMPn$ is the n-th voltage gain of the amp, $V_{BATTERYn}$ is the n-th battery voltage, and V_{OFFn} is the n-th offset voltage of the amp.
- N-th offset voltage V_{OFFn}

Each battery voltage $V_{BATTERYn}$ ($n = 1$ to 4) is thus calculated by following equation.

$$V_{BATTERYn} = \{(V_{BATn} - V_{OFFn}) / GAMPn \} \quad (n=1,2,3,4)$$

After the state of CTL3 and CTL4 are changed, a time between 25 μs and 250 μs is needed for the battery monitor amp to become stable.

Note: In the power down condition the battery monitor amp output is the V_{SS} level.

4. CTL pins

The S-8243 has four control pins. The CTL1 and CTL2 pins are used to control the COP and DOP pin output voltages. CTL1 takes precedence over CTL2. CTL2 takes precedence over the battery protection circuit. The CTL3 and CTL4 pins are used to control the VBATOUT pin output voltage.

Table.8 CTL1 and CTL2 Mode

Input		Output	
CTL1 pin	CTL2 pin	External discharging FET	External charging FET
High	High	OFF	OFF
High	Open	OFF	OFF
High	Low	OFF	OFF
Open	High	OFF	OFF
Open	Open	OFF	OFF
Open	Low	OFF	OFF
Low	High	Normal (1)	OFF (2)
Low	Open	Normal (1)	Normal (1)
Low	Low	OFF	Normal (1)

(1) : States are controlled by voltage detection circuit . (2) : Off state is brought after the overcharge detection delay time t_{CU} .

Table.9 CTL3 and CTL4 Mode

Input		Output	
CTL3 pin	CTL4 pin	V _{BATOUT} (A series)	V _{BATOUT} (B series)
High	High	V1 Offset	V1 Offset
High	Open	$V1 \times 0.2 + V1 \text{ Offset}$	$V1 \times 0.2 + V1 \text{ Offset}$
High	Low	Don't use.	V2 Offset
Open	High	Don't use.	$V2 \times 0.2 + V2 \text{ Offset}$
Open (3)	Open (3)	V2 Offset	V3 Offset
Open	Low	$V2 \times 0.2 + V2 \text{ Offset}$	$V3 \times 0.2 + V3 \text{ Offset}$
Low	High	V3 Offset	V4 Offset
Low	Open	$V3 \times 0.2 + V3 \text{ Offset}$	$V4 \times 0.2 + V4 \text{ Offset}$
Low	Low	Don't use.	Don't use.

(3) : CTL3 and CTL4 pins should be open when a microcomputer is not used.

■ Operation Timing Charts

1. Overcharge detection

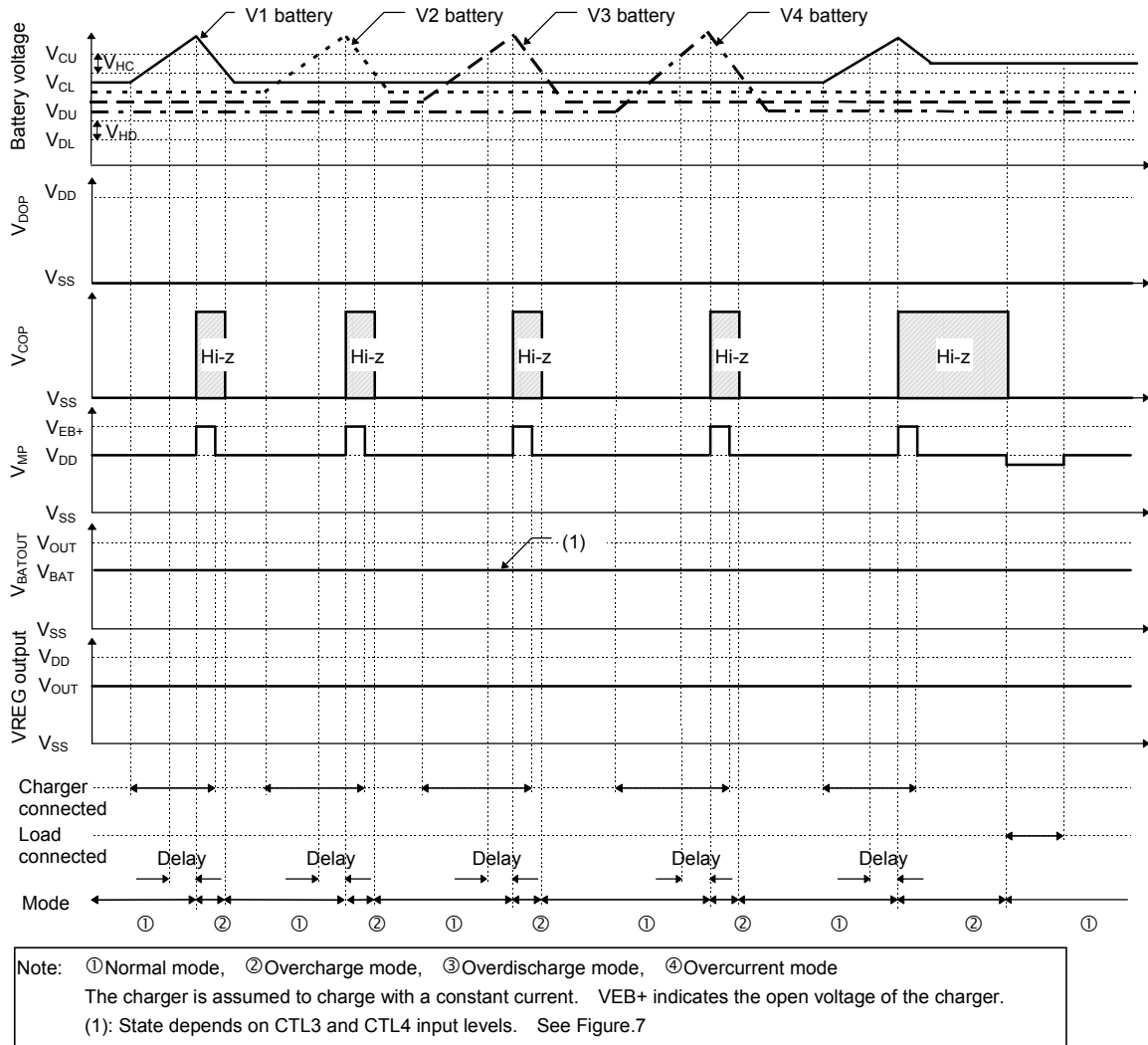

Figure 3

2. Overdischarge detection

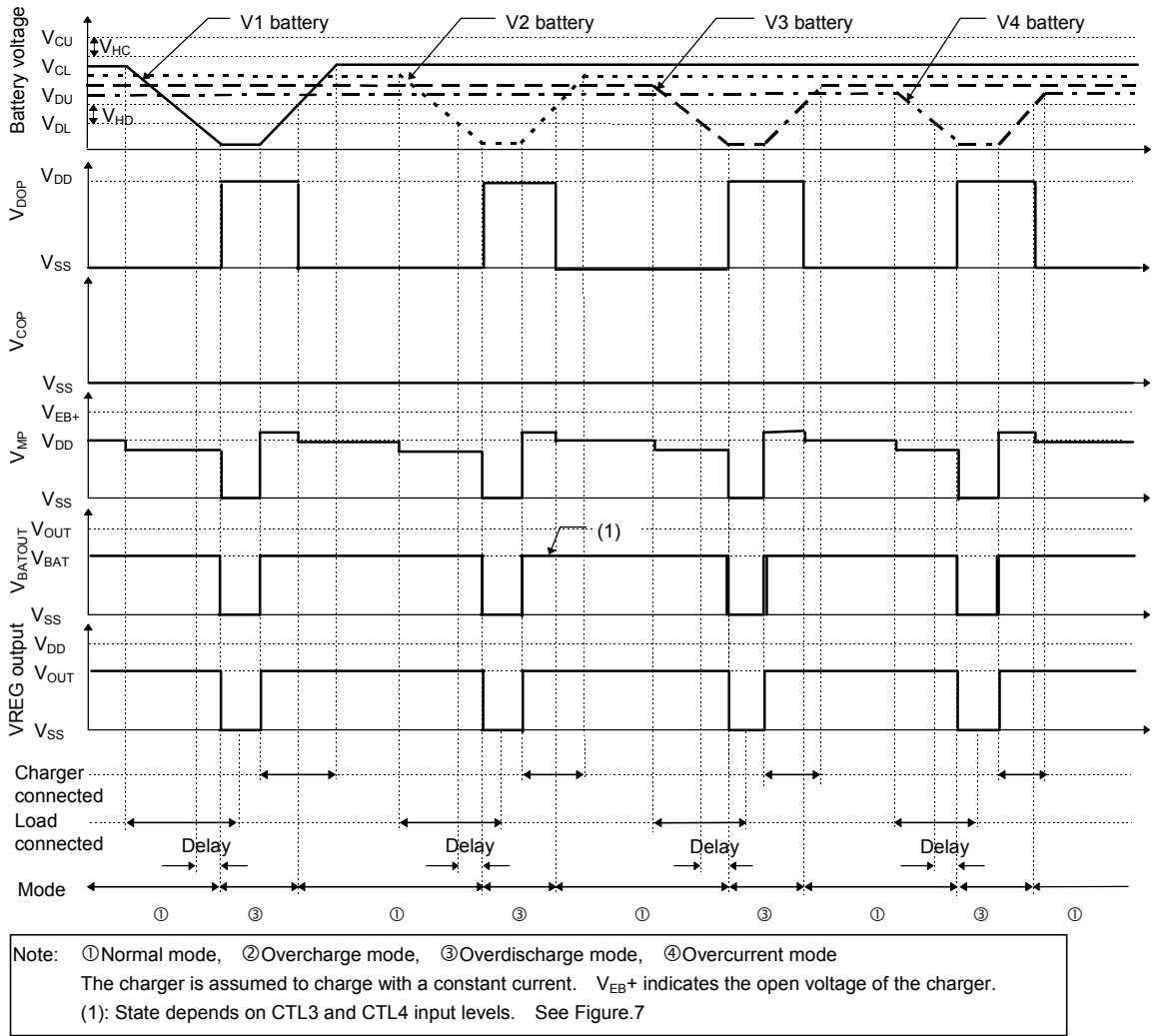

Figure 4

3. Overcurrent detection

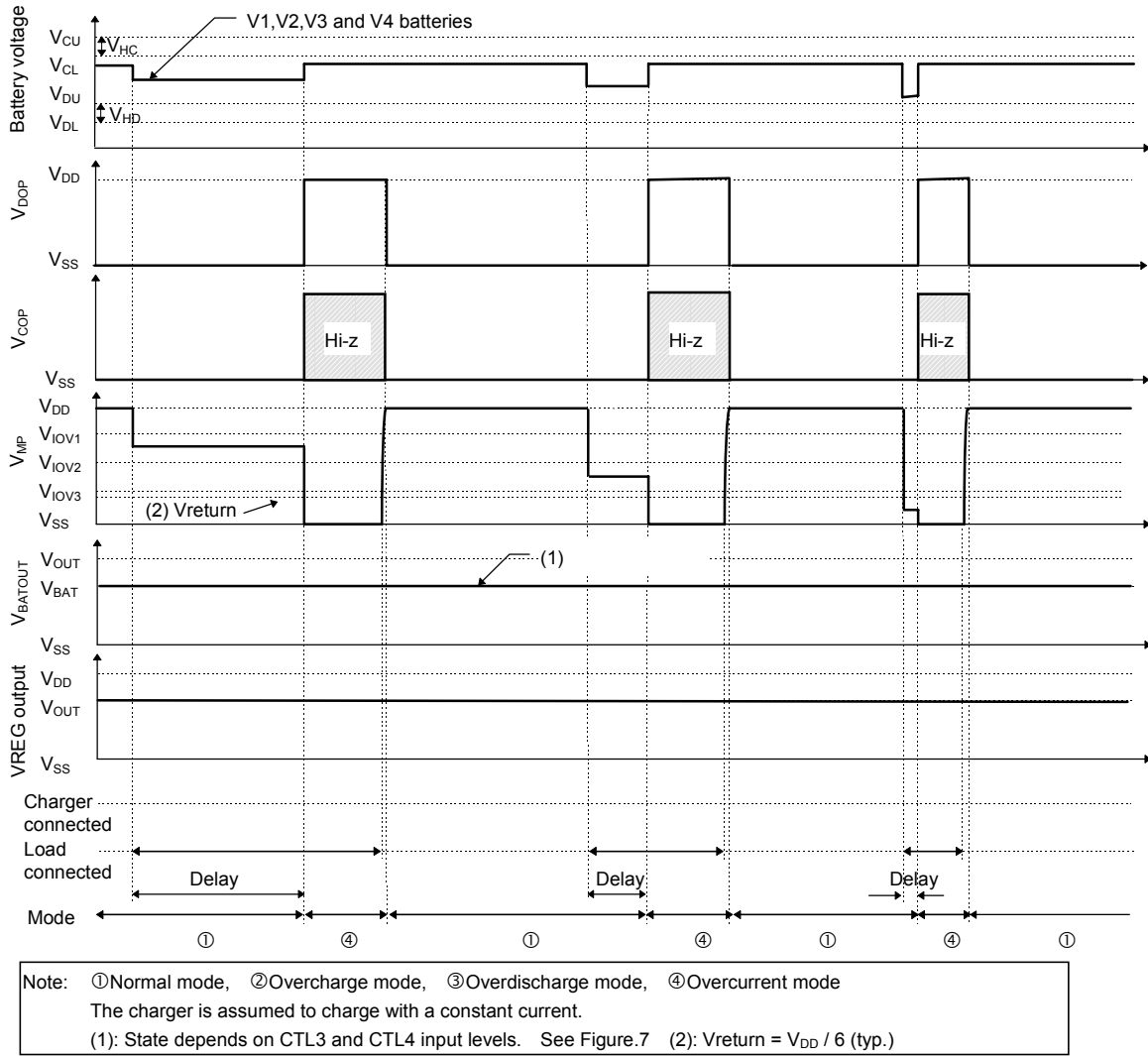

Figure 5

4. CTL1, CTL2 pin voltage

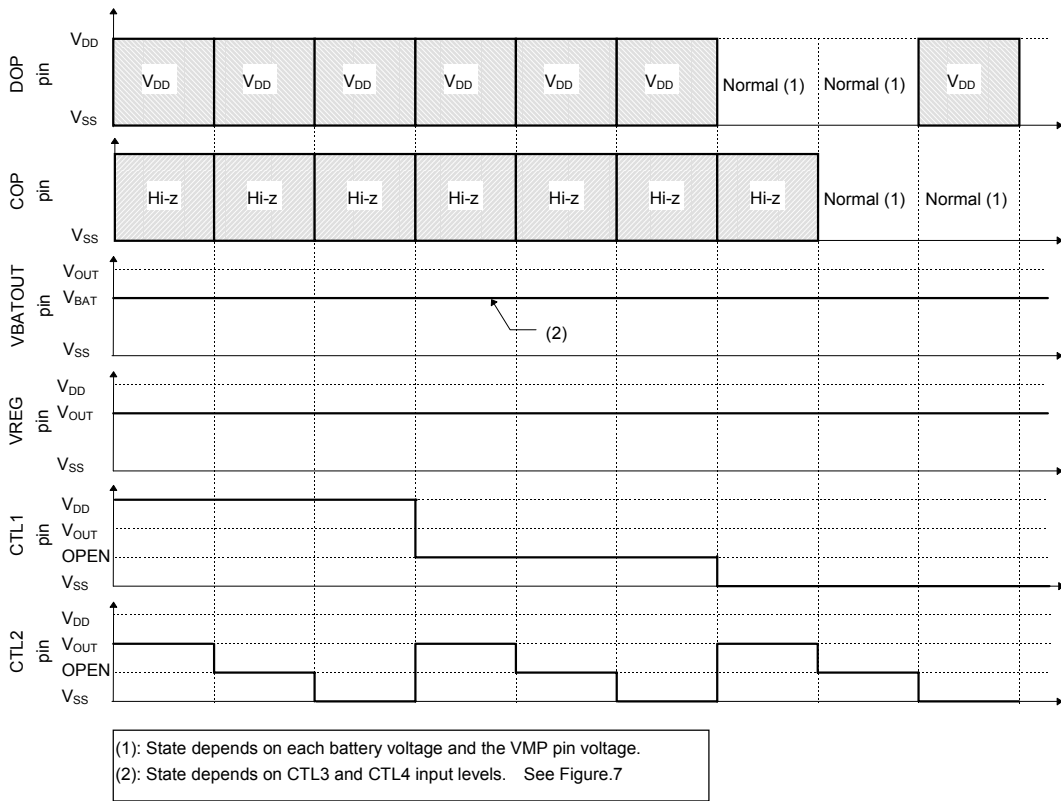

Figure 6

5. CTL3, CTL4 pin voltage

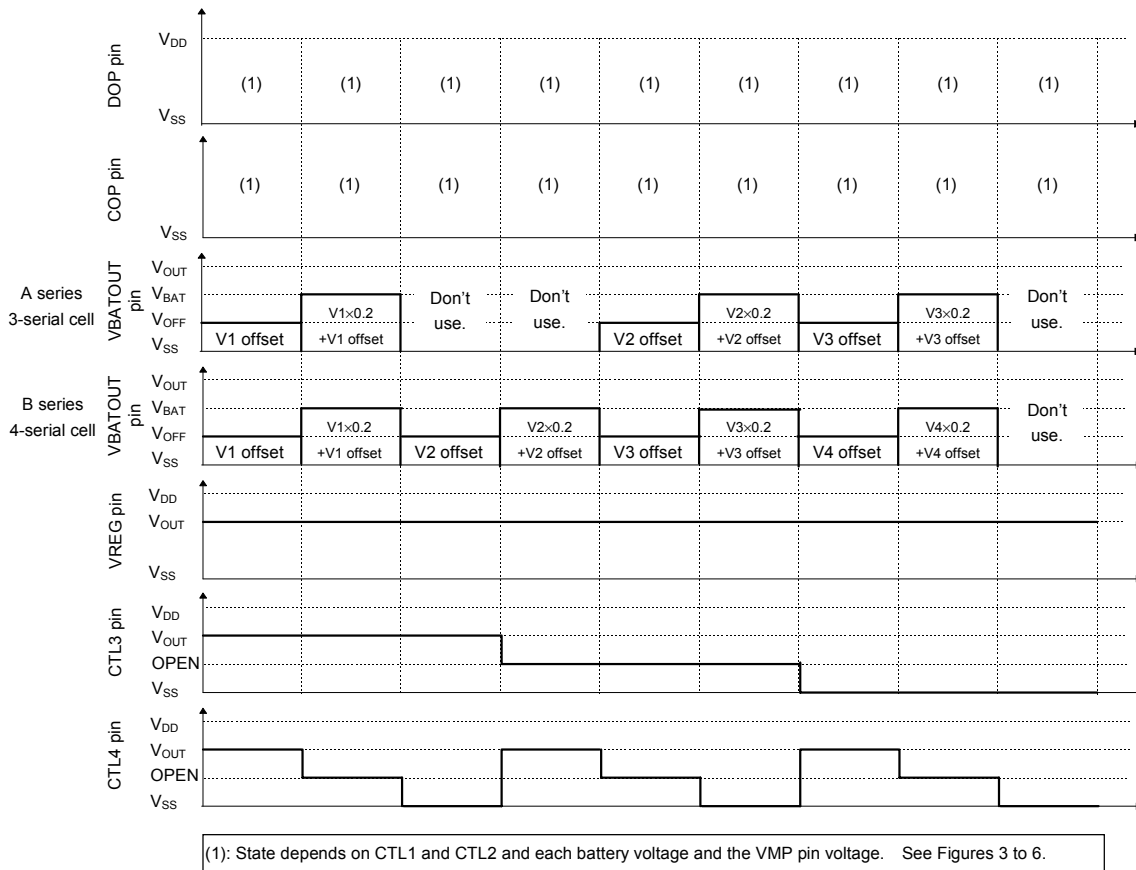

Figure 7

■ Standard circuit

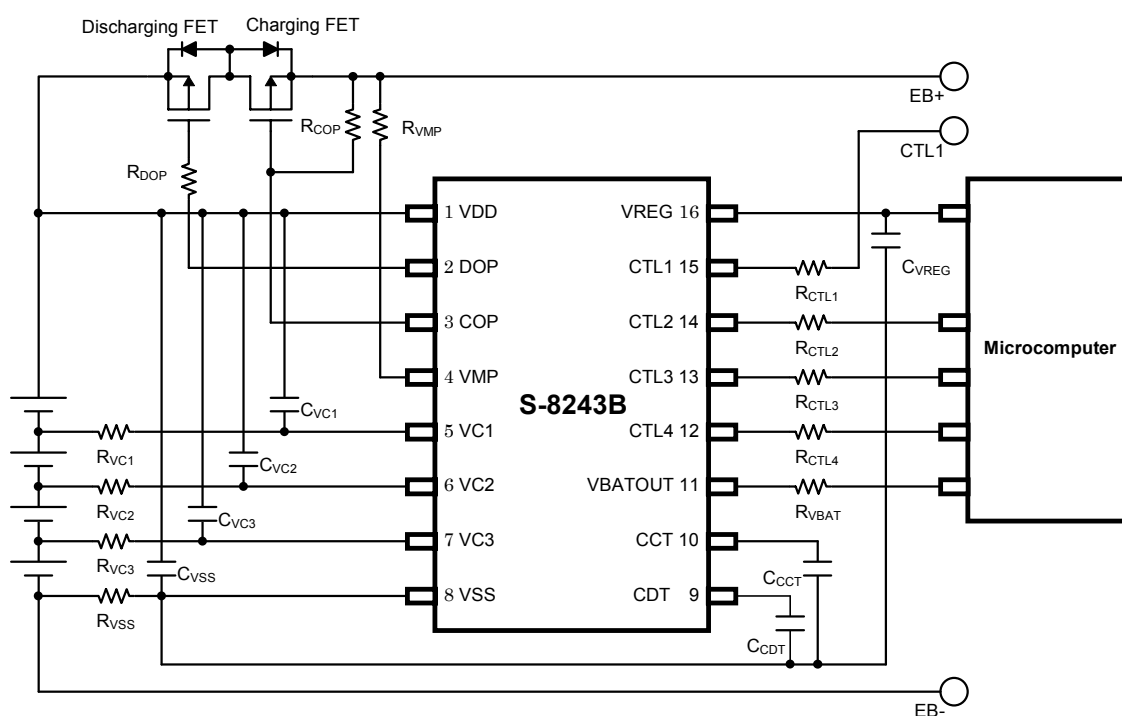

Figure 8 Standard circuit

Table 10. Recommended value for external parts

No.	Part	Recommended value	Range	unit
1	RVC1	1	0 to 1	kΩ
2	RVC2	1	0 to 1	kΩ
3	RVC3	1	0 to 1	kΩ
4	RVSS	10	0 to 10	Ω
5	RDOP	5.1	2 to 10	kΩ
6	RCOP	1	0.1 to 1	MΩ
7	RVMP	5.1	1 to 10	kΩ
8	RCTL1	0	0 to 100	kΩ
9	RCTL2	0	0 to 10	kΩ
10	RCTL3	0	0 to 10	kΩ
11	RCTL4	0	0 to 10	kΩ
12	RVBAT	0	0 to 100	kΩ
13	CVC1	0.047	0 to 0.22	μF
14	CVC2	0.047	0 to 0.22	μF
15	CVC3	0.047	0 to 0.22	μF
16	CVSS	4.7	0 to 10	μF
17	CCCT	0.1	more than 0.01	μF
18	CCDT	0.1	more than 0.02	μF
19	CVREG	4.7	0.68 to 10	μF

Note: No resistance should be inserted in the power supply pin VDD.

Standard circuit does not guarantee proper operations. Evaluation in actual application is needed to determine proper constants.

■ Precautions

- Pay attention to the operating conditions for input/output voltage and load current so that the power loss in the IC does not exceed the package power dissipation.
- Seiko Instruments Inc. shall not be responsible for any patent infringement by products including the S-8243 series, the method of using the S-8243 series in such products, the product specifications or the country of destination thereof.

■ Application circuits

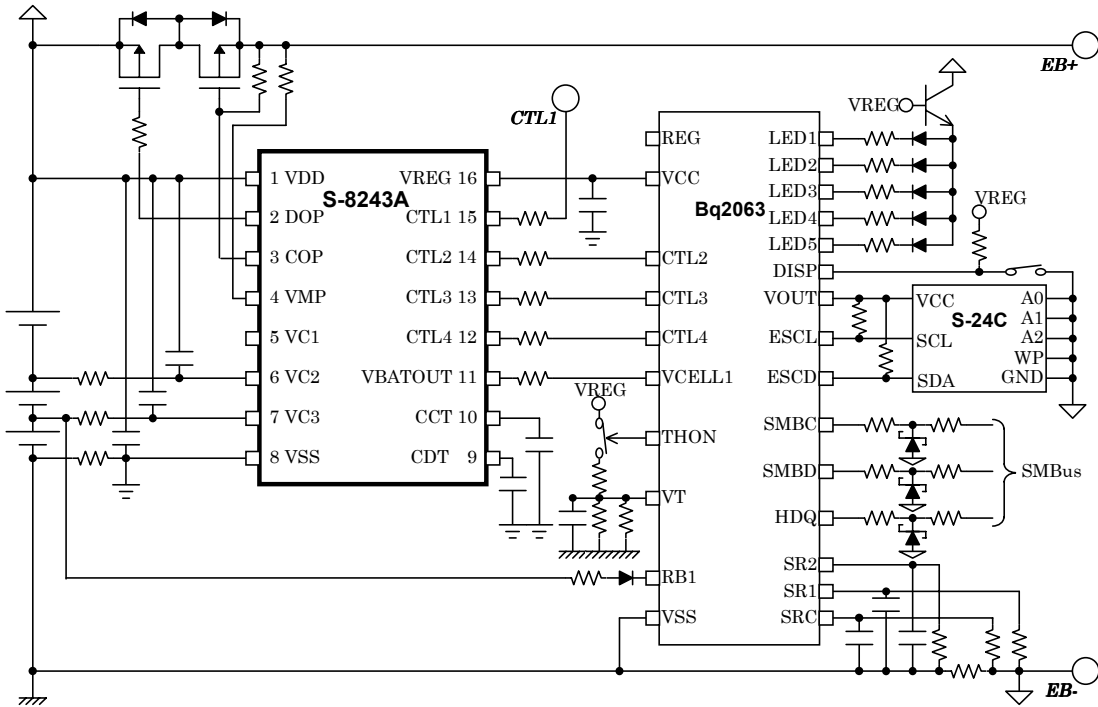

Figure 9 Application circuit 1

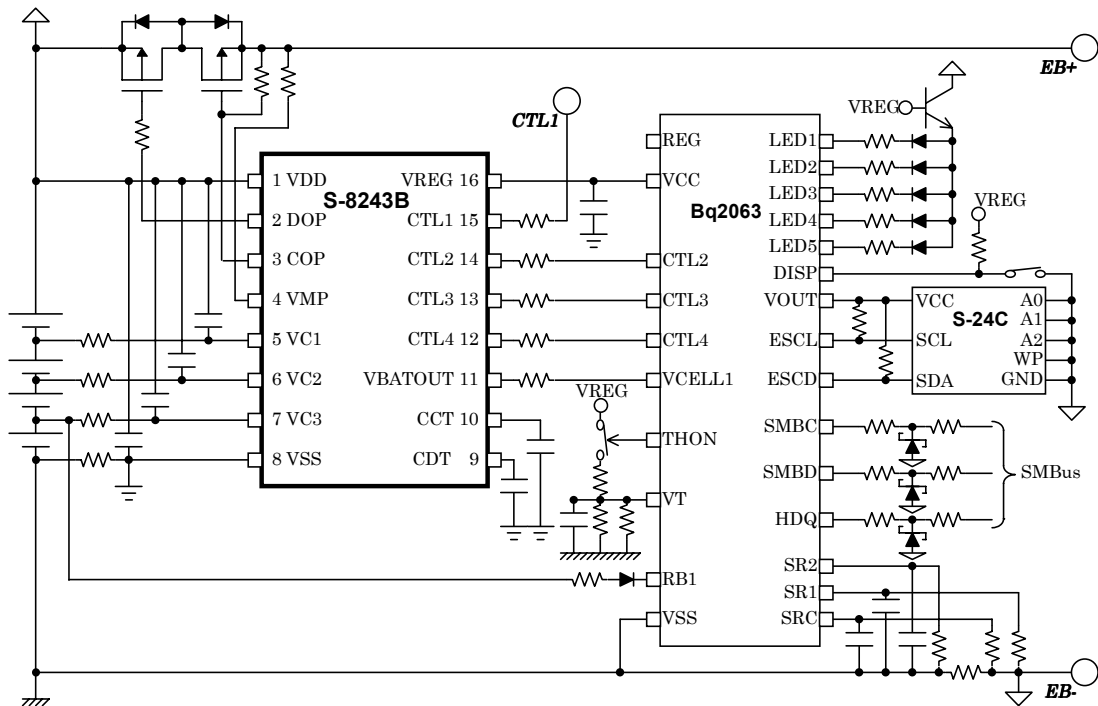

Figure 10 Application circuit 2

Note: The application circuits do not guarantee proper operations. Evaluation in actual application is needed to determine proper constants.

■ Typical Performance Curves

1. Current consumption

S-8243BAF

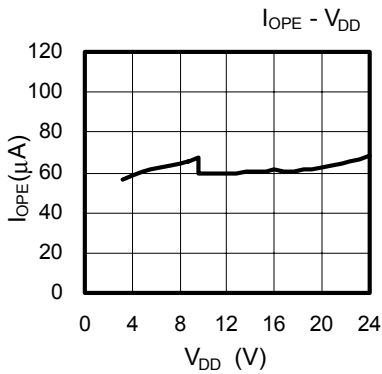

S-8243BAF

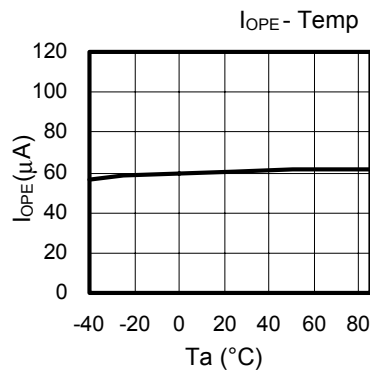

S-8243BAF

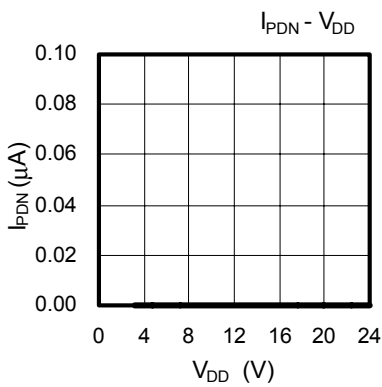

S-8243BAF

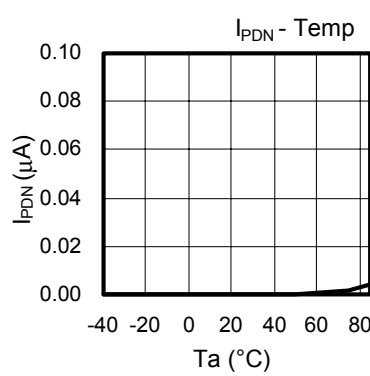

2. Overcharge detection/release voltage, overdischarge detection/release voltage, overcurrent detection voltages, and delay times

S-8243BAF

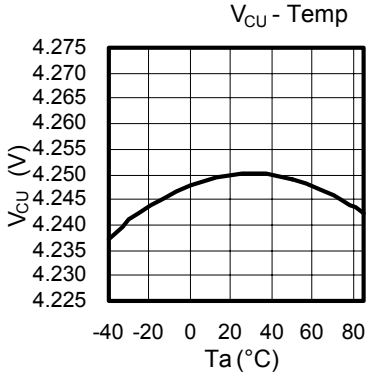

S-8243BAF

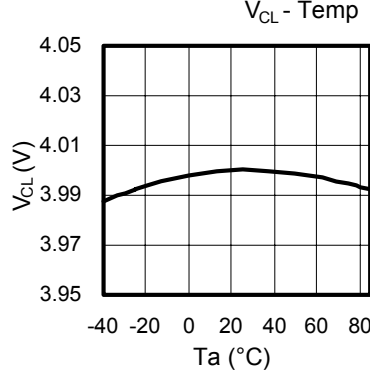

S-8243BAF

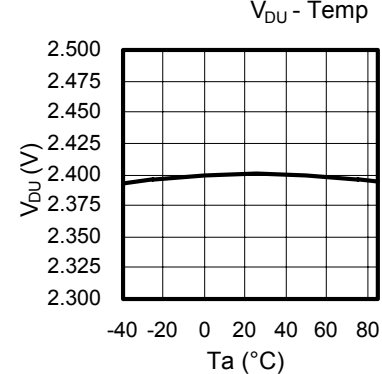

S-8243BAF

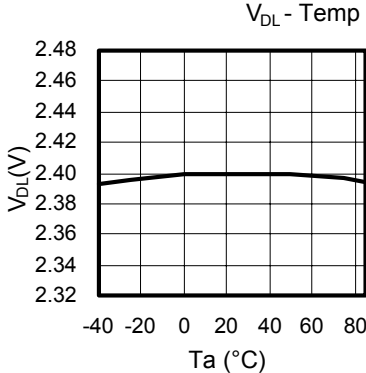

S-8243BAF

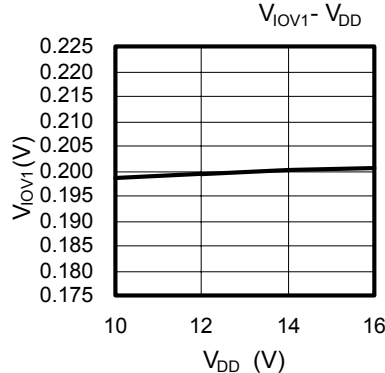

S-8243BAF

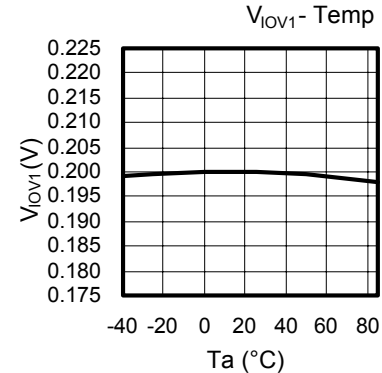

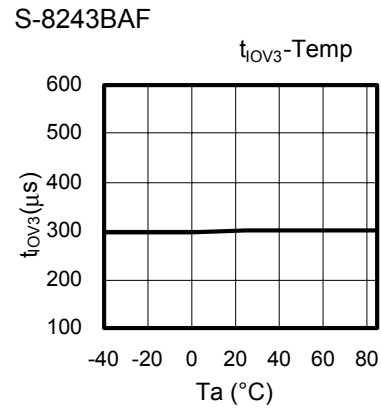
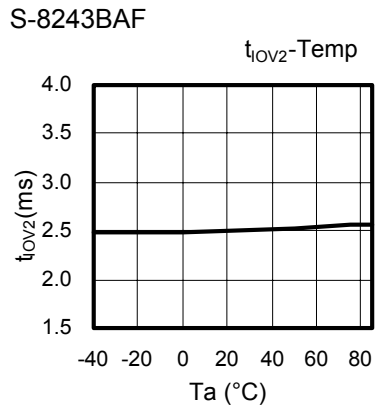
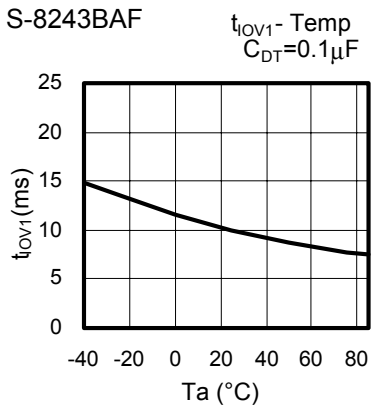
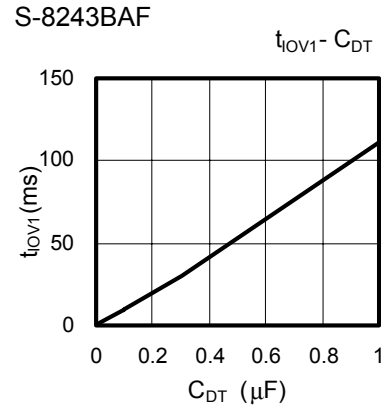
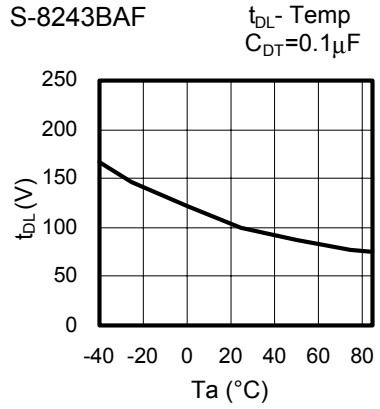
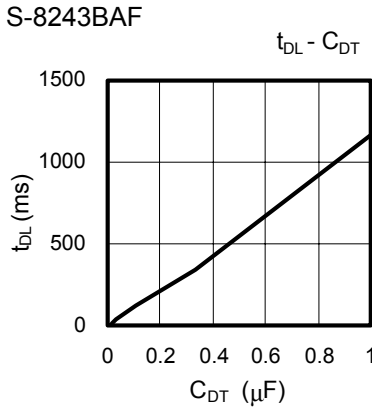
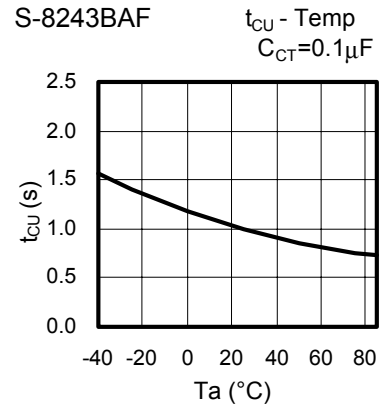
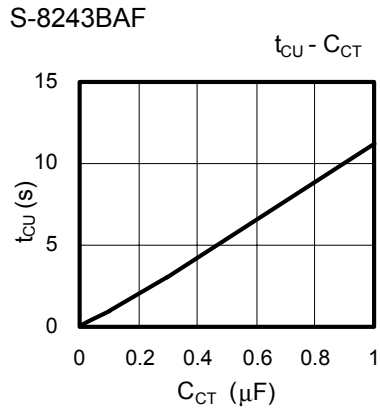
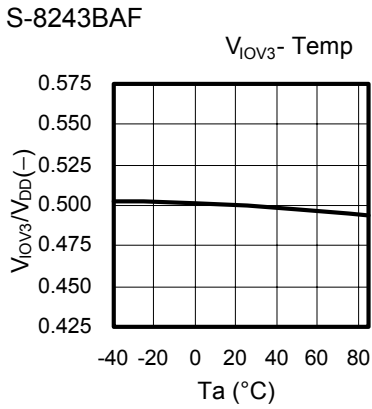
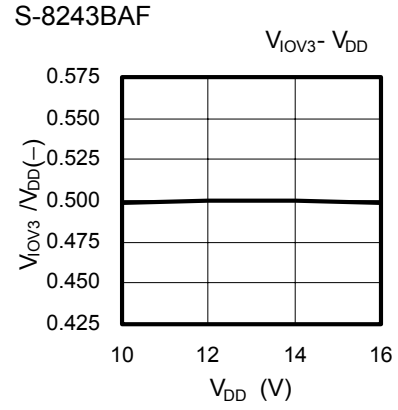
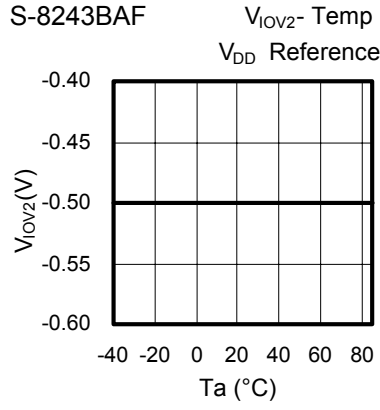
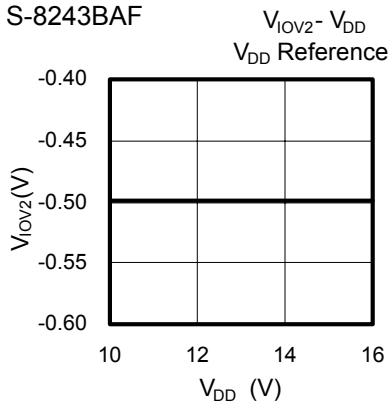

3. COP/DOP pin current

S-8243BAF

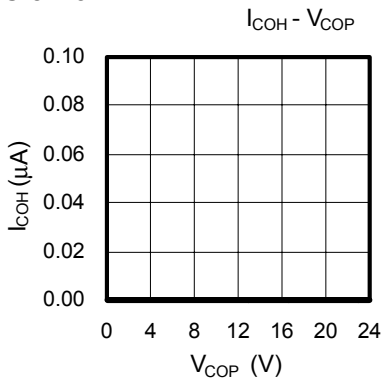

S-8243BAF

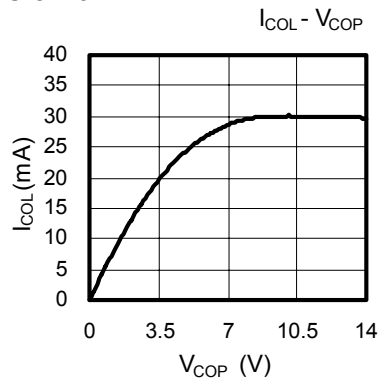

S-8243BAF

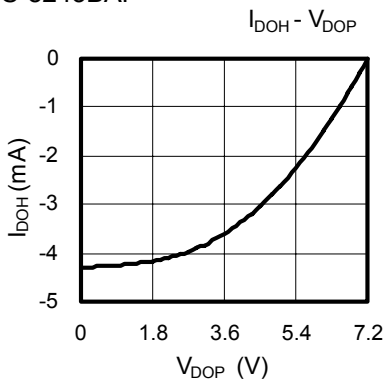

S-8243BAF

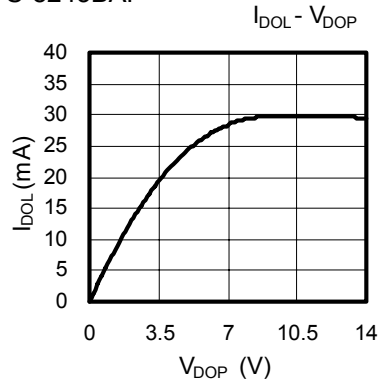

4. Voltage regulator

S-8243BAF

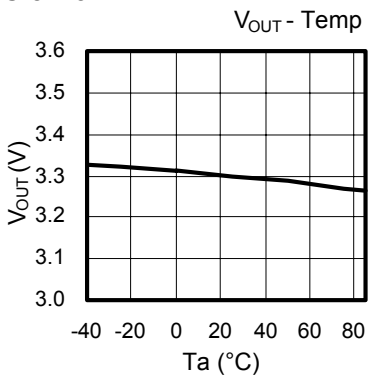

S-8243BAF

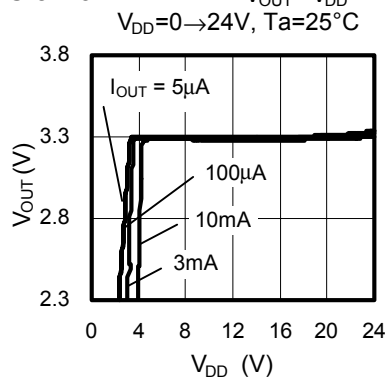

S-8243BAF

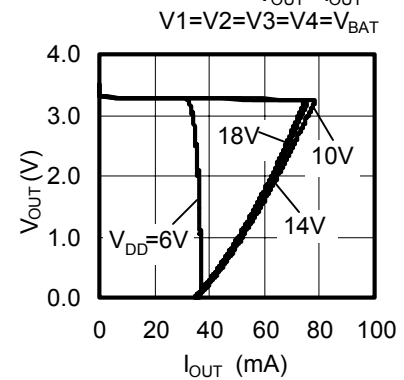

S-8243BAF

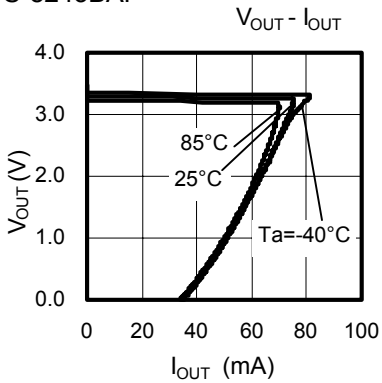

5. Battery monitor amp

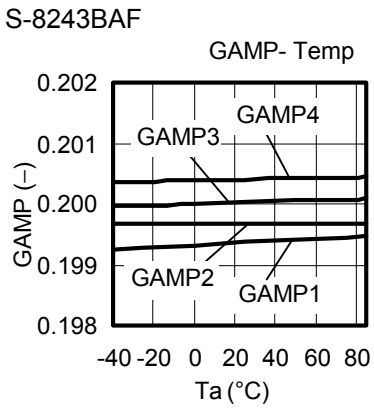
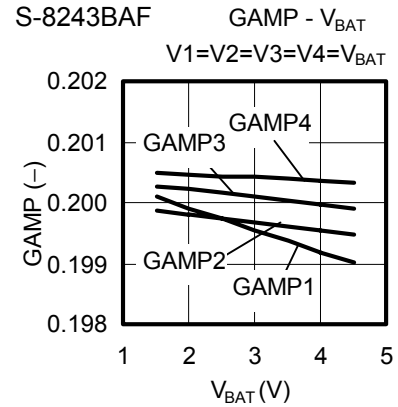
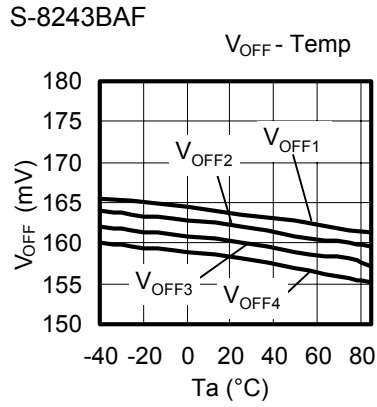
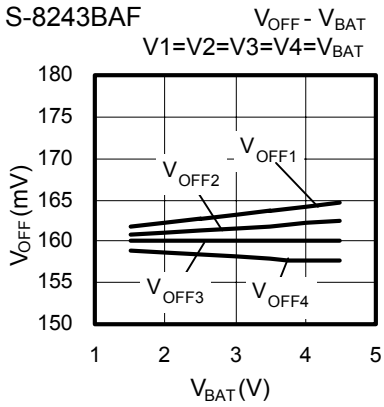

16-Pin TSSOP

FT016-A Rev.1.0 020107

Dimensions

Unit:mm

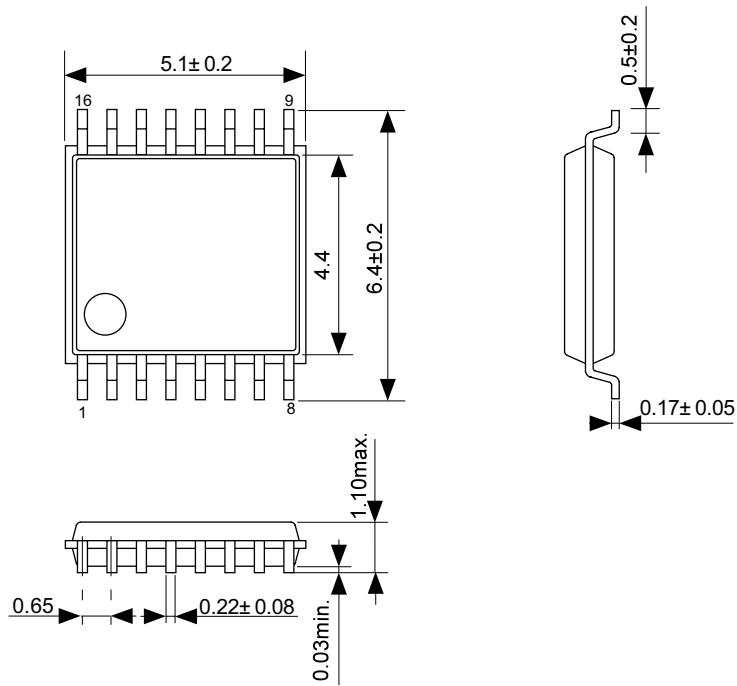

No.: FT016-A-P-SD-1.0

Taping Specifications

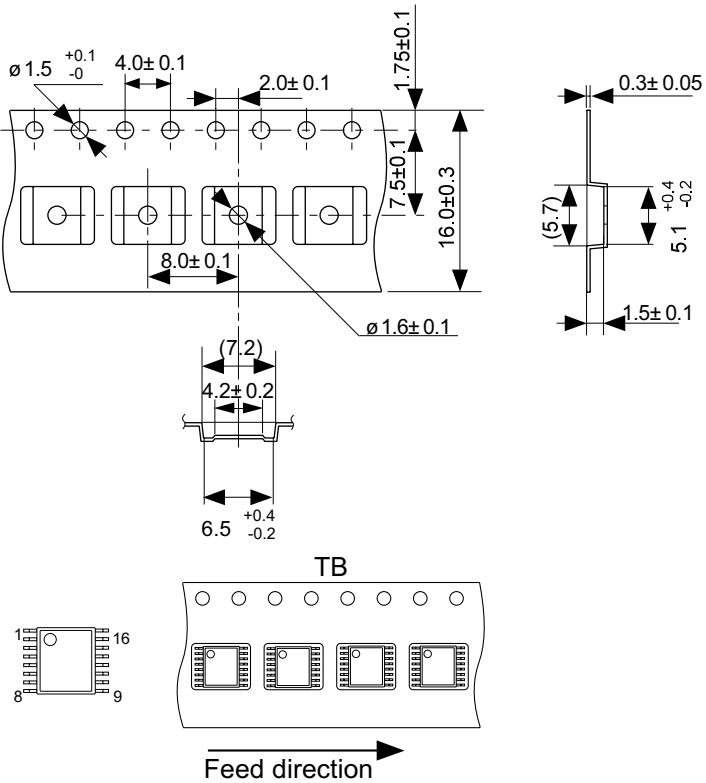

No.: FT016-A-C-SD-1.0

Reel Specifications

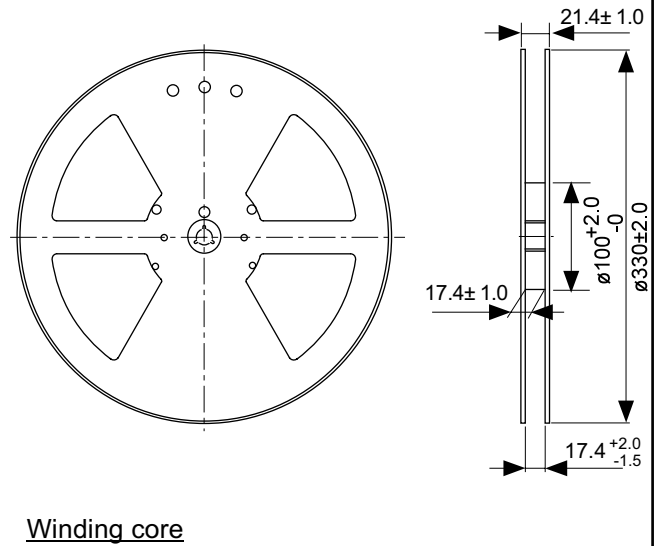

Winding core

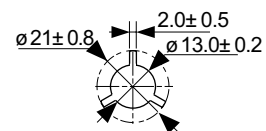

No.: FT016-A-R-SD-1.0

- The information described herein is subject to change without notice.
- Seiko Instruments Inc. is not responsible for any problems caused by circuits or diagrams described herein whose related industrial properties, patents, or other rights belong to third parties. The application circuit examples explain typical applications of the products, and do not guarantee the success of any specific mass-production design.
- When the products described herein are regulated products subject to the Wassenaar Arrangement or other agreements, they may not be exported without authorization from the appropriate governmental authority.
- Use of the information described herein for other purposes and/or reproduction or copying without the express permission of Seiko Instruments Inc. is strictly prohibited.
- The products described herein cannot be used as part of any device or equipment affecting the human body, such as exercise equipment, medical equipment, security systems, gas equipment, or any apparatus installed in airplanes and other vehicles, without prior written permission of Seiko Instruments Inc.
- Although Seiko Instruments Inc. exerts the greatest possible effort to ensure high quality and reliability, the failure or malfunction of semiconductor products may occur. The user of these products should therefore give thorough consideration to safety design, including redundancy, fire-prevention measures, and malfunction prevention, to prevent any accidents, fires, or community damage that may ensue.